

SpartanII+CR(D) only 25MHz-50MHz X'tal OSC & VCO & PLL

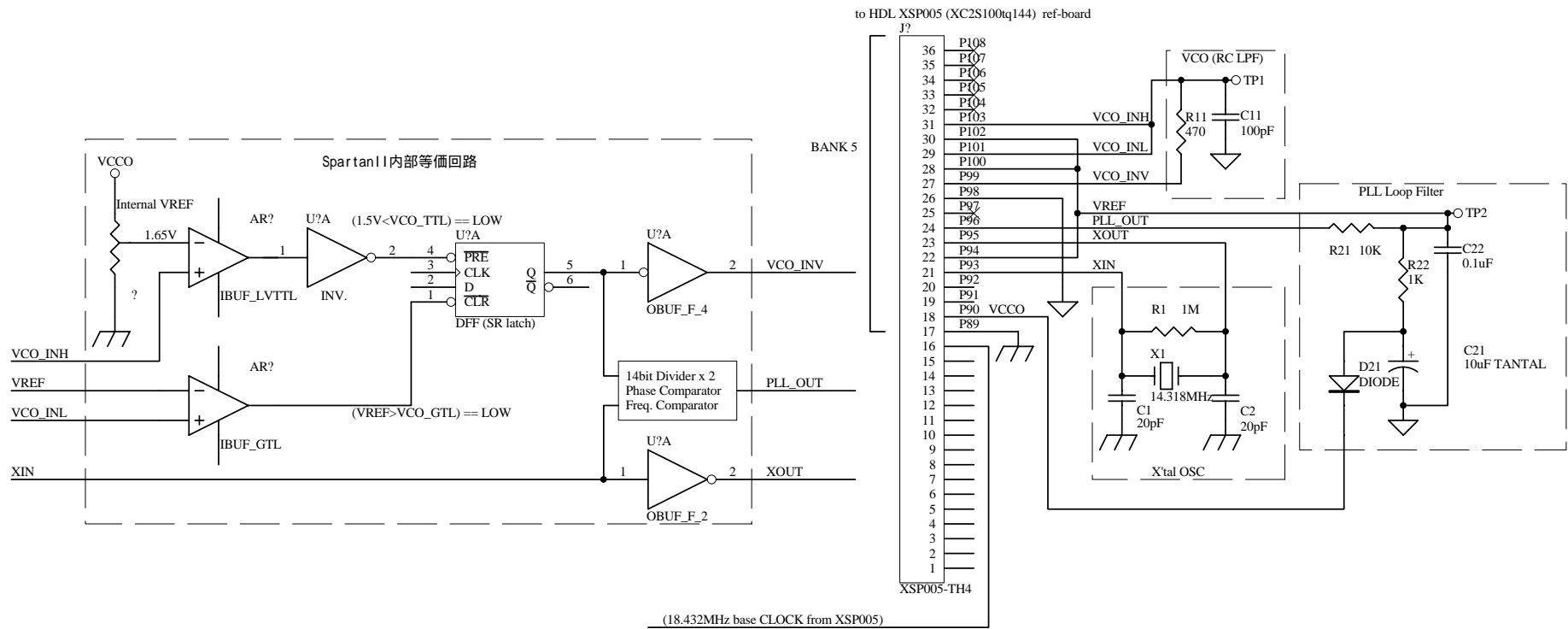

Title XSP005 Programmable Oscillator		T&A	
Size: A4	Number:	Revision:	
File: C:\usr\SCH\pacman\pacman.ddb - \$Date: 2003-11-23 15:20:20\$ Time: 15:20:20 Sheet 1 of 1			Error : t&a\BMP file not found.